

Design and Simulation of Dual Band Planar Inverted F Antenna (PIFA) For Mobile Handset Applications

K. Rama Krishna¹, G Sambasiva Rao², P.R.Ratna Raju.K³

V R Siddhartha Engineering college¹, India

Madanapalle Institute of Technology and Science^{2,3}, India

ABSTRACT

In this paper dual band Planar Inverted F Antenna (PIFA) is presented for mobile handset applications at dual frequencies. PIFA is a flat structure, simple and easy to fabricate. The idea of U-shaped slot technique is introduced into the basic rectangular patch antenna for higher GSM frequency. The impedance bandwidth covers GSM 900 and GSM 1900 bands. The PIFA covers a bandwidth of 31.9MHz (0.88-0.911GHz) or about 3.5% with respect to the resonance frequency at 0.89GHz. For the higher resonant mode the impedance bandwidth is 112.7MHz (1.873-1.985GHz) or about 5.83% with respect to resonance frequency of 1.93 GHz. The PIFA has a gain of 2.59dB and 5.12dB at lower and higher resonating frequencies respectively. PIFA is analyzed using High Frequency Structure Simulator (HFSS).

KEYWORDS

Planar Inverted F antenna, Return loss, GSM 900, GSM 1900

1.INTRODUCTION

For rapid development of Cellular Communication an antenna which meets the requirement of a mobile phone user is very demanding. Monopole $\lambda/2$ antenna was used earlier to face these challenges. Half wavelength monopole antennas have high radiation towards user head, easy to physical damage and unable to produce multi resonance frequencies. Later monopole antenna is replaced by Planar Inverted F Antenna (PIFA). It has advantages of desired cross polarization in order to receive both horizontal and vertical polarization, easy feeding, simple to fabricate and easy to place in mobile terminal as its size is less ($\lambda/4$). It has less spurious radiation towards user head. Planar Inverted F antenna is a radiating element shorted at one end from patch to ground. This shorting plate makes the PIFA to resonate at $\lambda/4$. In present scenario minimum size of the antenna is challenging one. For PIFA with $\lambda/4$ resonance, same basic properties can be obtained as that of normal half wavelength patch antenna.

2.PLANAR INVERTED F ANTENNA (PIFA)

Planar Inverted F antenna is developed from mono pole antenna. Inverted L is realized by folding down the mono pole in order to decrease the height of the antenna at the same time maintaining identical resonating length. When feed is applied to the Inverted L, the antenna appears as

Inverted F. The thin top wire of Inverted F is replaced by planar element to get the Planar Inverted F antenna. This sequence is clearly observable in Fig 1.

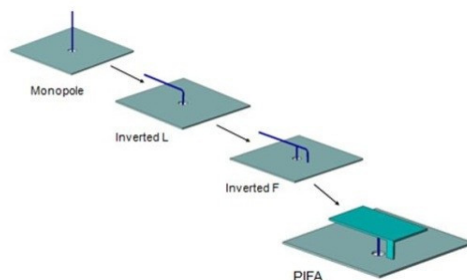

Fig 1. PIFA from monopole

2.1 PIFA DESIGN

PIFA consists of ground plane, radiating patch above the ground plane and shorting plane. A coaxial probe feed is given between the ground plane and patch element. Top radiating patch plane is folded at one edge of a patch and shorted to the ground plane to decrease the antenna length as shown in Fig 2. The size of the patch and resonating frequency can be determined by the following equations

$$L_1 + L_2 - W = \lambda/4 \quad (1)$$

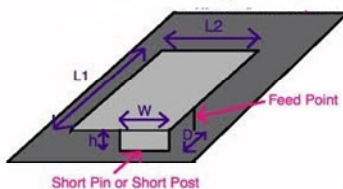

Fig 2. Basic PIFA

$$f_r = \frac{c}{\lambda} = \frac{c}{4\sqrt{\epsilon_r} \cdot (L_1 + L_2 - W)} \quad (2)$$

$$f_r = \frac{c}{4(L_1 + L_2 - W)\sqrt{\epsilon_r}} \quad (3)$$

Where L_1 = length of the patch, L_2 = Width of the patch, C = Velocity of light, ϵ_r = dielectric constant, λ = wavelength. PIFA has moderate (or) high gain in both horizontal and vertical polarization. Generally most of the wireless systems use vertical polarization. Even if transmitter antenna polarization is not known, still the signal is received with good strength. When antenna orientation is not fixed, a signal with good gain (greater than 10 dB) is received and signal strength is calculated by summing up the horizontal and vertical components.

3.ANTENNA DESCRIPTION

The design of the proposed antenna is shown in Fig 3. It consists of patch plane, ground plane, shorting plate and feeding post connected to the ground plane. Between dielectric medium and patch plate, air is placed. Resonating frequency can be calculated if the initial patch and shorting pin sizes are known using Eq (3).

The dimensions of PIFA are 22mm × 40 mm and is located 5mm above the phone printed circuit board (PCB).The PCB layer has relative permittivity of 4.4 (FR4_epoxy) with size 100×40×1.2 mm. To provide RF ground, PCB is metalized on its back surface. By using optimization, the PIFA is operated at resonant frequencies of 0.89GHz and 1.93GHz to cover the dual band of GSM900 and GSM1900. The proposed antenna is fed by microstrip feeding structure. U-shaped slot is introduced on patch plane in order to get dual resonance. Basically coaxial probe feed is used for PIFA. Here in this antenna Microstrip line feed of width 2mm is used as shown in Fig 3.

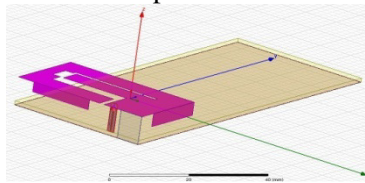

Fig 3. PIFA design

Two folded patches are introduced in order to get the high gain at resonant frequencies. First folded patch of dimension 17 mm × 4 mm is introduced along the width of the patch. Similarly second folded patch of dimension 18 mm × 3mm is introduced along the length side of rectangular patch.

Antenna geometry is shown in Table 1 and Antenna description is shown in Table 2

Table 1: PIFA parameters

Length of the patch (L_1)	40 mm
Width of the patch (L_2)	22mm
Width of the shorting pin (W)	6.7mm
Height of the substrate (h_{sub})	1.2 mm
Length of the ground plane	100mm
Width of the ground plane	40mm

Table 2: Antenna description

Shape	Rectangular
Frequency of operation	GSM 900 (880-960)MHz GSM 1900 (1850-1990)MHz
Dielectric constant of the substrate	FR4 Epoxy (4.4)

Height of the dielectric substrate	1.2 mm
Feeding method	Microstrip feed
VSWR	2:1
Gain	(2-6) dB

The dimensions of different slots are clearly mentioned in the top view of antenna as shown in Fig 4.

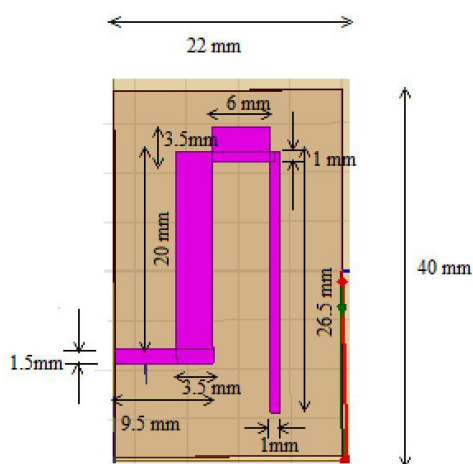

Fig 4. Top view of PIFA

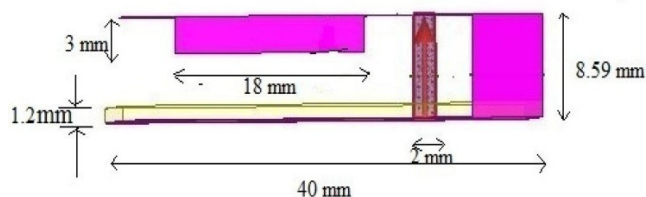

Fig 5. Front View

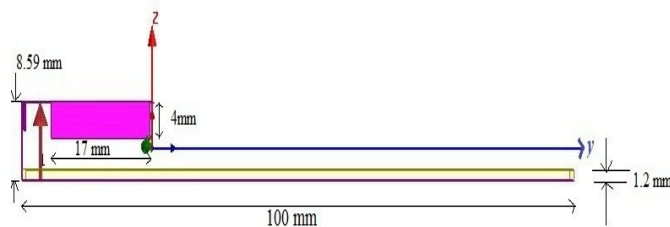

Fig 6. Side View

4.SIMULATION RESULTS

The Planar Inverted F antenna was analyzed and optimized with the HFSS 13 simulator software. Since generally PIFA is a high frequency device driven model is used while designing antenna in HFSS software.

4.1 The effect of slot on patch for PIFA

The U-shaped slot on patch plane makes the PIFA antenna resonating at dual frequencies. Initially U-shaped slot is introduced on patch plane. Dual resonating frequencies are generated out of GSM range. Using parametric analysis that is by varying the length and width of U-shaped slot dual resonating frequencies are obtained in the GSM range.

For dimensions as shown in Fig 5 (Top view) of PIFA, dual resonating frequencies are obtained at 0.89GHz and 1.93GHz in the GSM 900 and GSM 1900 standards with return loss of -33.36dB and -29.67dB respectively.

4.2 Return loss

The lesser return loss the more properly antenna radiating. -10dB value can be considered as the acceptable return loss. For bandwidth calculations -10dB is considered as acceptable return loss. The return loss of a PIFA with normal microstrip feed is -33.36dB and -29.6dB at frequencies 0.89GHz and 1.93GHz respectively as shown in Fig 7.

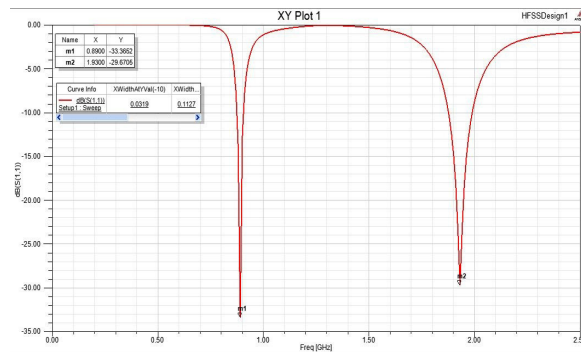

Fig 7. Return loss of PIFA

The impedance bandwidth is 31.9MHz (0.88-0.911GHz) or about 3.5% with respect to the resonance frequency at 0.89GHz. For the higher resonant mode the impedance bandwidth is 112.7MHz (1.873-1.985GHz), or about 5.83% with respect to resonance frequency of 1.93 GHz. The acquired bandwidths can sufficiently cover the bandwidth requirement for GSM 900 and GSM 1900 standards.

4.3 VSWR

Voltage standing wave ratio (VSWR) should be 2:1 for good radiator. A maximum gain of 2.59 dB is achieved in lower band with VSWR value of 1.0439 indicating a good impedance matching (perfect matching VSWR=1) which implies that almost all input power could be transmitted to the patch. In the higher band, the peak gain reaches to 5.12dB with VSWR value of 1.06 indicating a good impedance matching. For both higher and lower bandwidths range the VSWR is 2:1 as shown in Fig 8.

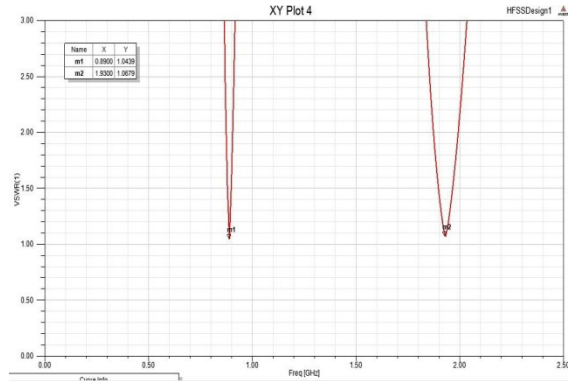

Fig 8. VSWR of PIFA

4.4 The effect of shorting plane width

The effect of shorting plane (shorting pin) width can be analyzed using parametric analysis. As short plane width increases from 2mm to 6.7mm, the return loss increases at lower & higher bands and return loss curves are shifting right side of the graph or resonating frequencies are increased as shown in Fig 12. Resonating frequency of PIFA can be determined using Eq (3). Return loss variation for different short plane widths are as shown in Table 4.

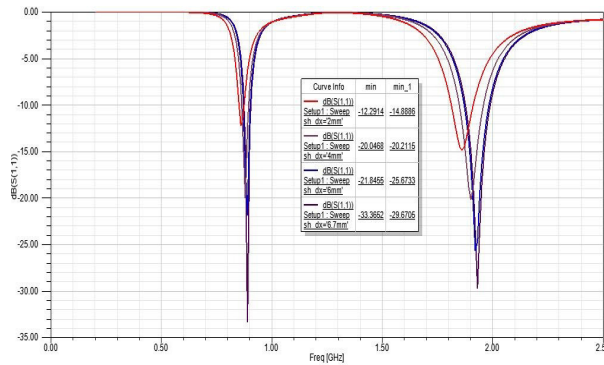

Fig 9: Variation of return loss with frequency for different short plane width

Table 4: short plane width VS Return loss

Shorting plane width(sh_w)	Return Loss (dB) at lower band(0.89GHz)	Return Loss(dB) at higher band(1.93GHz)
2mm	-12.29	-14.8
4mm	-20.04	-20.211
6mm	-21.8455	-25.6733
6.7mm	-33.3652	-29.6705

4.5 The effect of substrate height

The effect of substrate height can be analyzed using parametric analysis. As substrate height increases from 1.2mm to 4.4mm, impedance bandwidth and return loss at lower and higher bands are decreasing and the return loss curve moving left side of the graph. The variation of return loss and impedance bandwidth is tabulated as shown in Fig 10.

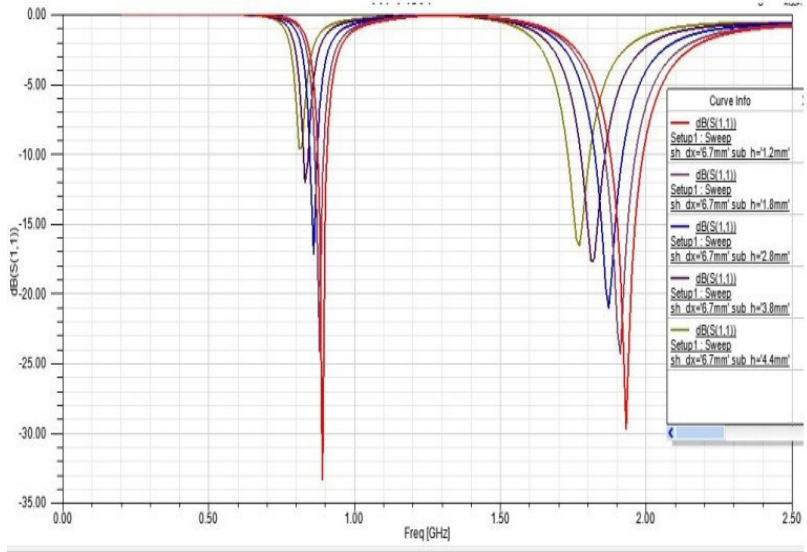

Fig 10. Return loss corresponding to substrate height variation

Table 5: Return loss & Band width corresponding to substrate height variation

Substrate height (mm)	Return loss at (0.89GHz) dB	Return loss at (1.93GHz) dB	Impedance band width at lower band (MHz)	Impedance band width at higher band (MHz)
1.2	-33.3652	-29.67	31.9	112.7
1.8	-24.1126	-24.337	30.5	106.5
2.8	-17.2341	-21.0618	25.5	95.8
3.8	-12.115	-17.633	16.6	83.5
4.4	-9.6	-16.56	0	75.5

4.6 The effect of change of dielectric constant (ϵ_r)

When dielectric constant of the material increases, the lower bandwidth is approximately constant where as the higher bandwidth decreases as shown in Table 6. It is also observed that return loss increases as dielectric constant increases.

Table 6: The effect of change of dielectric constant

dielectric constant (ϵ_r)	Return loss at 0.89GHz (dB)	Return loss at 1.93GHz (dB)	Impedance bandwidth at lower band(MHz)	Impedance bandwidth at higher band(MHz)
2.2	-20.33	-30.89	31.3	116
3.2	-26.31	-29.44	31.4	113.6
4.4	-33.36	-29.67	31.9	112.7

5.RADIATION PATTERN

The radiation pattern refers to the directional (angular) dependence of the electric field (magnetic field) strength of the antenna. At lower resonating frequency radiation pattern is omni-directional

i.e. radiation pattern is figure 8 pattern in elevation plane and uniform in azimuthal plane as shown in Fig 11 with a gain of 2.59 dB. At higher resonating, the radiation pattern is nearly uniform in azimuthal plane and directional in elevation plane as shown in Fig 12 resembles omni- directional pattern with a gain of 5.12 dB.

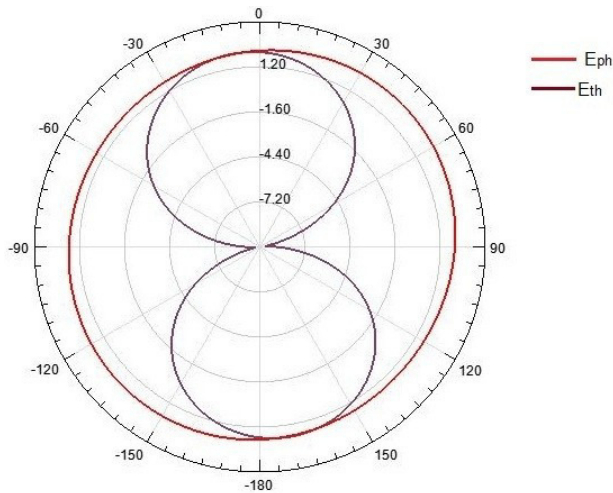

Fig 11. Radiation pattern for $f_r = 0.89\text{GHz}$

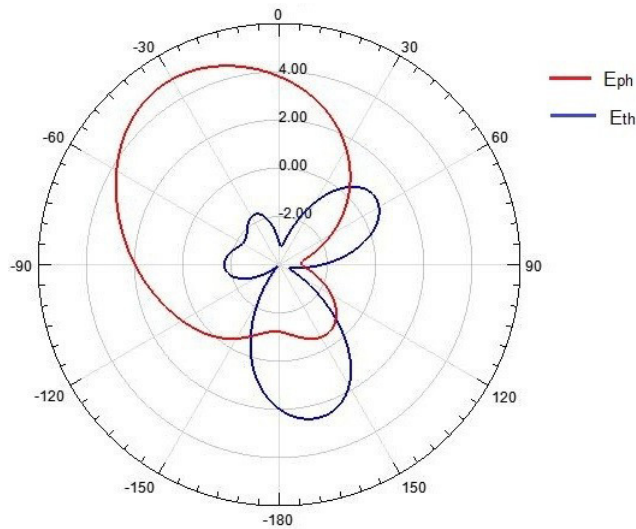

Fig 12. Radiation pattern for $f_r = 1.93\text{GHz}$

5.1 Directivity

Maximum gain in a given direction is called directivity. If antenna efficiency is one directivity and antenna gain are interchangeable. When resonance frequency is 0.89GHz, a directivity of 2.55dB is achieved as shown in Fig 13. When resonance is frequency 1.93GHz, a directivity of 4.882dB is obtained as shown in Fig 14.

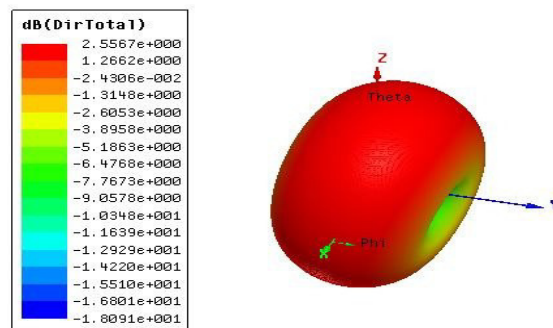

Fig 13. Directivity plot for $f_r = 0.89\text{GHz}$

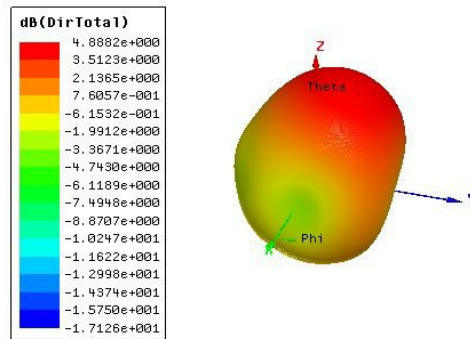

Fig 14. Directivity plot for $f_r = 1.93\text{GHz}$

5.2 Surface current distribution

The simulated current distributions on the antenna body for both resonant frequencies are represented in Fig 15. At both resonating frequencies, the current distribution has a maximum close to the shorting pin similar to the standard PIFA. It is clearly observed from the Fig 15(a) that the radiation is more at the slots at 0.89 GHz with a maximum value of surface current distribution (A/m) of more than $0.27 \times 10^3 \text{ A/m}$. For the higher resonant frequency, the magnitude of surface current is observed to be less than the current distribution at lower resonant frequency as shown in Fig 15(b).

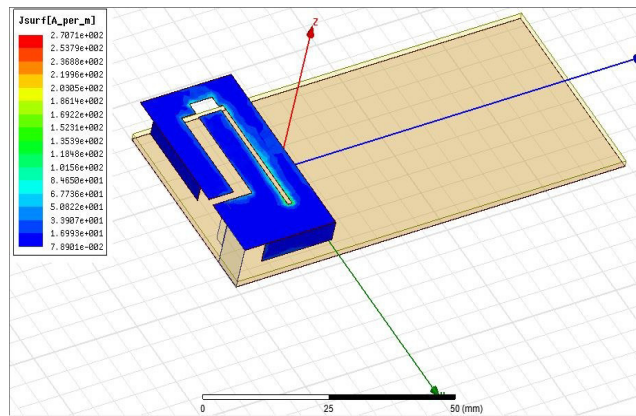

Fig 15 (a): Surface current distribution at 0.89GHz

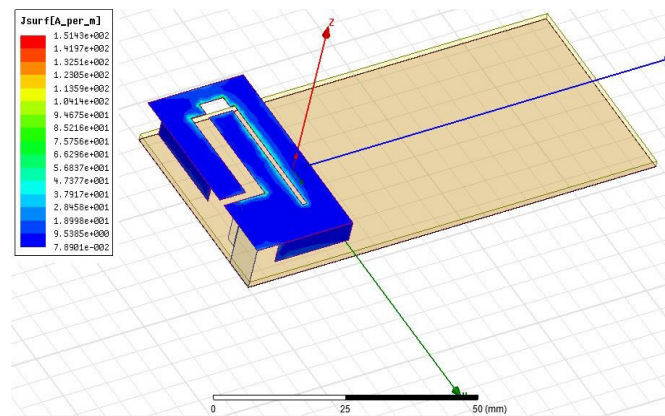

Fig 15 (b): Surface current distribution at 1.93GHz

6.CONCLUSION

In this project Planar Inverted Antenna (PIFA) is designed and simulated. The PIFA covers a bandwidth of 31.9MHz (0.88-0.911GHz) and 112.7MHz (1.873-1.985GHz) and lower and higher bands with directivity of 2.55dB and 4.88dB at lower and higher resonating frequencies 0.89GHz and 1.93GHz respectively.

REFERENCES

- [1] Saad Wasmi Luhaib, Kaydar M. Quboa and Bareq M. Abaoy "Design and Simulation Dual-Band PIFA Antenna for GSM Systems" 9th International Multi conference on systems 2012.
- [2] Z. D. Liu, P. S. Hall, and D. Wake, "Dual-Frequency Planar Inverted-F Antenna", IEEE Trans. Antennas Propagation, Vol. 45, No. 10, pp.1451-1458, Oct. 1997.
- [3] M.Komulainen, M. Berg, H. Jantunen, E. T. Salonen, "A Frequency Tuning Method for a Planar Inverted-F Antenna", IEEE Trans. Antennas Propagation, Vol. 56, No. 4, April 2008.
- [4] P. Nepa, G. Manara, A.A. Serra, G. Nenna. "Multiband PIFA for WLAN mobile terminals", IEEE Antennas Wireless Propagation Letters, 2005, vol.4, pp. 349 – 350.
- [5] S.-H. Yeh, K.-L. Wong, T.-W. Chiou, and S. T. Fang, "Dual-band planar inverted F antenna for GSM/DCS mobile phones," IEEE Trans. Antennas Propagation, vol. 51, no. 5, pp. 1124-1126, May 2003.
- [6] Adnan Iftikhar, Muhammad Nadeem Raftiq, "A Dual band balanced planar inverted F antenna (PIFA) for mobile applications" IEEE Proc-Microwave, Antennas Propagation, Vol.149, No.2, pp. 85-91, 2013
- [7] Dongsheng Qi, Binhong Li, and Haitao Liu "Compact triple-band planar inverted-F antenna for mobile handsets", Microwave and Optical Technology Letters, Vol. 41, No. 6, June 20, 2004.
- [8] P. Salonen, M. Keskilampi, and M. Kivikoski, "Single-Feed Dual-Band Planar Inverted-F Antenna with U-Shaped Slot", IEEE Trans. Antennas and Propagation, Vol. 48, No. 8, pp. 1262-1264, Aug. 2000.
- [9] N. Misran, M. M. Yunus and M.T. Islam, "Small Dual-Band Planar Antenna with Folded Patch Feed", Journal of Applied Sciences Research, 6(12), 2010.
- [10] Sandeep K Veeravalli, K.Shambavi, Zachariah C Alex "Design of Multi band Antenna for Mobile Hand set", Proceedings of 2013 IEEE conference on Information and Communication Technologies (ICT 2013).
- [11] "Antennas for all applications" 3rd edition by John D Krauss
- [12] "Antenna theory analysis & Design" ,3rd edition by Constantine A. Balanis
- [13] High frequency structure simulator(HFSS) 13 version.

Authors

G Sambasiva Rao was born in india, A.P in 1984. He received B.E(ECE) from Narasaraopeta Engineering College, Narasaraopeta. And M.Tech(Microwave Engg) from University of Kerala, Trivandrum. He has a 6 years of teaching experience. 4 International Journals, 02 International Conference in his credit. Presently working as an Assistant professor in MITS, Madanapalle,A.P



P.R.Ratna Raju.K was born in india, A.P in 1984. He received B.E(ECE) from Sir C.R.Reddy College of Engineering, Eluru. And M.Tech(Communication systems) SVNIT, Surat, Gujarat .He has a 6 years of teaching experience. Presently working as an Assistant professor in MITS, Madanapalle,A.P



K Ramakrishna was born in india, A.P in 1988. He received B.E(ECE) and M.Tech(Microwave Engg) from VR Siddhartha Engineering College, Vijayawada. He has a 2 years of teaching experience. 1 International Journals, 02 International Conference in his credit. Presently working as an Assistant professor in Srinidhi institute Technolog, Hyderabad,Telangana.