

MONO AND MULTI BAND EBG STRUCTURES : A COMPARITIVE STUDY

D.Rohith¹, N.Pallavi², B.Annapurna³ and K.Praveen Kumar⁴

^{1,2,3,4}Assistant Professor Department of Electronics and Communication
Engineering,India.

ABSTRACT

In the current paper, mono and multi EBG structures for wider bandwidth are presented. For every EBG mentioned in this paper, metallic patches of regular shapes are selected as unit elements and these patches are altered to get additional inductance and capacitance which provides lower cut-off frequency and large bandwidth. The surface wave attenuation of EBG structures are juxtaposed with conventional EBG of mushroom type. The variation of transmission response due to unit element size, via diameter and distance between unit elements is shown. Out of these proposed EBG's the square patch is small, the fractal EBG has wider bandwidth. The square patch with mono disconnected loop type slot and the fractal are multi band. The designing of microwave circuits and the antennas can be done using these EBGs.

KEYWORDS

Microstrip line, EBG, surface waves, Patch, Mono Band and double-band

1. INTRODUCTION

Surface Waves are undesirable in any antenna design. The parameters like gain, radiation pattern and efficiency of the antenna are degraded by the surface waves as these waves travel along the surface plane. In antenna array design due to these waves mutual coupling is caused which produce blind scanning angles. The augmentation of the dielectric constant makes surface waves more dominant which can be observed in the MMIC RF circuits [1-6]. UWB band pass filters are one of the widely used band pass filters due to their capability of high speed data transmission. However, their performance is affected by the surface waves as the surface waves produce spurious stop bands[7]. Multilayer pcb's also suffer from electromagnetic interference and signal integrity problems caused by stimulation of resonance modes by concurrent switching noise[8-10].

These issues can be resolved by the implementation of Electromagnetic Band gap structures. Electromagnetic band gap structures possess periodic metal patches on a dielectric substrate or a combination of dielectric only. EBG structures have a property of obstructing the surface waves at a specific frequency and also reflect back any incoming wave without any phase shift. These characteristics of EBG structures enhance the characteristics of an antenna [1-3]. EBG's are used for the enhancement of the gain, isolation and diversity gain in MIMO systems. Further they are used to obtain notched characteristic in Ultra Wideband Antenna[11] and suppression of noise and EMI in high speed circuits[12-15]. Theoretical analyses and practical models are present in references[16-18]. Large number of techniques are proposed on designing of dual band and multi band structures but they have a limitation of narrow bandwidth[19-22]. In [19] To produce a heterogeneous band the a slot of double U type is prepared in the patch. In [20] a fractal structure creates a double band characteristic, where as a spiral type structure is utilized for creation of multiband characteristic.

In the present paper, mono band and double band EBG structures with wide bandwidth are proposed. To obtain double band EBGs the cyclical nature of micro strip circuits is utilized. Alternative circuits of the mentioned EBGs are also presented and also the transmission responses of the EBGs are juxtaposed with a traditional mushroom type EBG. In the second section, mono band EBGs are mentioned and explained whereas in the third section double band EBGs are mentioned. The FR-4 substrate having dielectric constant 4.4 is used as the material. These are used in high speed circuits for reduction of noise and EMI and in antennas for boosting the bandwidth, gain. The simulation of these EBG's is done by the Ansoft HFSS and CST Microwave studio. The construction and testing of EBG's is done to confirm the results.

2. SINGLE BANDEBG

Here, three types EBG's namely the cross hair, Swastika and hexagonal patch are discussed and analysed through microstrip line method. The juxtaposition of EBG's in the aspects of resonance frequencies and bandwidths is done with a conventional mushroom type EBG. The schematic of EBG is demonstrated in Figure 1 and it consists of two substrates, patch and via. The two extremes of the 50 ohms line are linked to two ports and the S21 is calculated using appropriate stimulation.

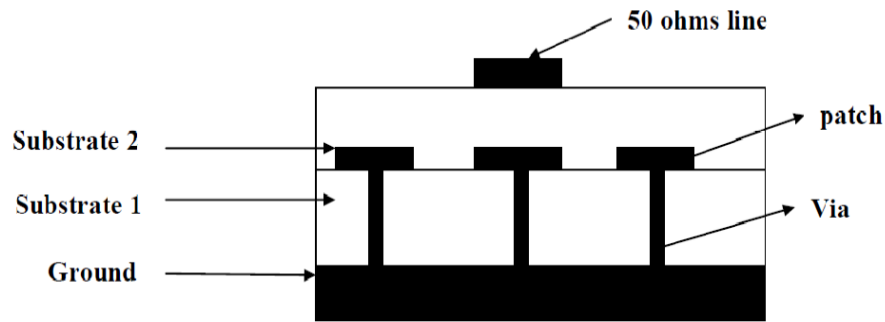

Figure1. Schematic of EBG

Mushroom Type EBG

This is a three dimensional EBG with a cylindrical via. The transmission characteristics further relies upon the width of the substrate and its material. Fig. 1 demonstrates a mushroom type EBG and its alternative circuit model. Fig. 2 demonstrates the mushroom type EBG's transmission response is altered with various patch sizes and the distance between the unit elements is considered to be 1 mm, the via diameter 0.6 mm and width of the substrate is 0.8 mm. It is clear from figure that an augmentation the patch size boosts the capacitance value and causes the shifting of the stop band towards the lower frequency side. The capacitance, inductance and resonance frequency are represented by (1), (2) and (3) respectively [2].

$$C = \frac{W\epsilon_0(1+\epsilon_r)}{u} \cosh^{-1} \left(\frac{W+g}{g} \right) \quad (1)$$

$$L = 2 * 10^{-7}h \left[\ln \left(\frac{2M}{r} \right) + 0.5 \left(\frac{2r}{M} \right) - 0.75 \right] \quad (2)$$

$$f_o = \frac{1}{2u\sqrt{LC}} \quad (3)$$

Where ‘W’ represents the side length of the patch, ‘g’ denotes the distance between the unit elements, ‘h’ denotes thickness of the substrate, ‘r’ denotes radius of the via, ϵ_0 and ϵ_r denotes permittivity of free space and relative permittivity respectively.

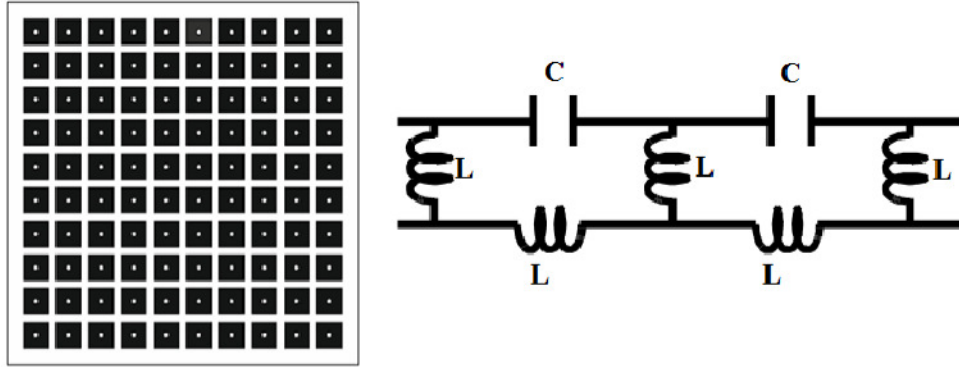

Figure1.(a) Mushroom type EBG (b) Equivalent circuit of Mushroom type EBG

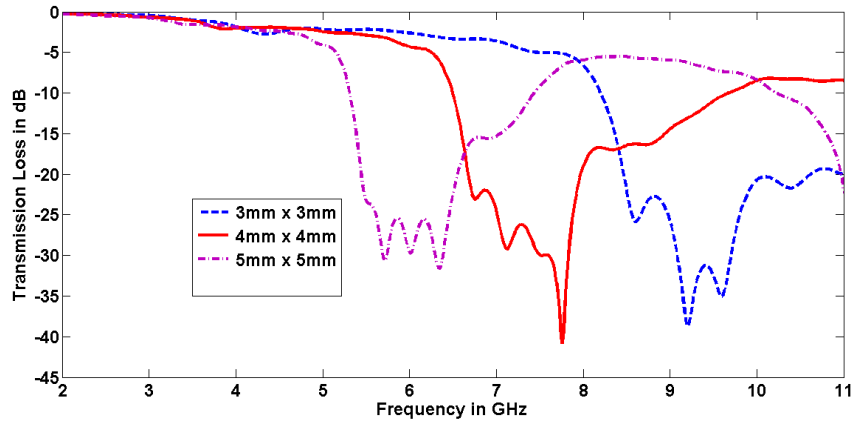

Figure2. Simulated transmission response of Mushroom type EBG for different element size (Substrate thickness=0.8 mm, via diameter =0.6 mm, Gap between unit elements=1 mm)

Cross Hair Type EBG

Fig. (3a) demonstrates a cross hair type EBG obtained by alteration of the mushroom type EBG having a patch and micro strip lines. An additional inductance than the mushroom type EBG is present due to micro strip lines. The diameter of the via is 0.6 mm.. Fig. (3b) demonstrates how the transmission response of this EBG is altered for various widths of the micro strip lines used. An augmentation in the width decreases the inductance value which makes the resonance frequency move towards the higher frequency region. Fig. 4 demonstrates the impact of the alteration of the separation ‘g’ of the unit elements on the transmission response of cross hair EBG. The reduction in separation of unit elements augments the capacitance value which causes the stop band to relocate towards the lower region. For maximum bandwidth, the ideal value of gap is found to be 0.8 mm.

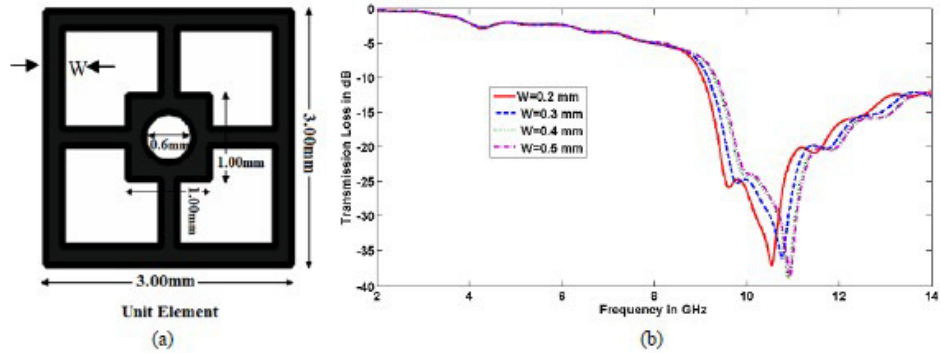

Figure 3. Cross hair type EBG (a) Unit element (b) Effect of variation of the width ‘W’ of the microstrip line on the transmission response of the EBG ($g=1$ mm, unit element size = 3 mm x 3 mm)

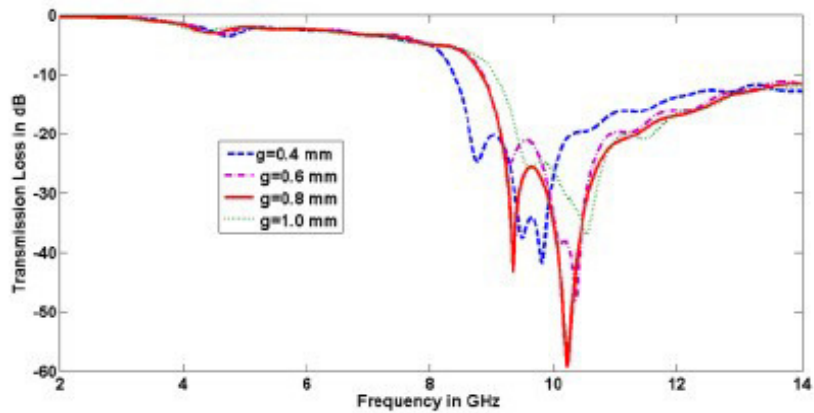

Figure 4. Effect of variation of gap between the unit elements ‘g’ on the transmission response ($w=0.2$ mm, Unit element size = 3 mm x 3 mm)

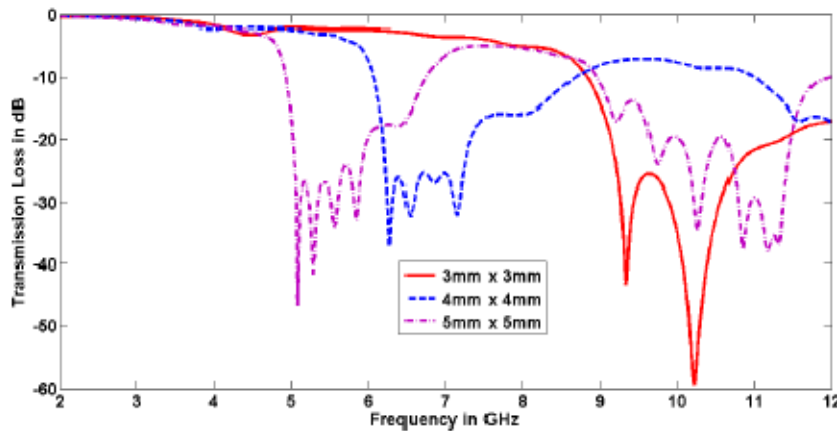

Figure 5. Impact of unit element size on the transmission response ($W=0.2$ mm, $g=0.8$ mm)

Swastika type EBG

This EBG produces capacitance due to which better resonance is generated than the cross hair.. Figure (6a) demonstrates unit element of the swastika type EBG and a prototype . Figure (6b) demonstrates the alternate circuit. The swastika type EBG is prepared on the same substrate (FR-

4). The diameter of via is taken as 0.6 mm. Figure 7 demonstrates transmission response of the swastika type EBG. The calculated band of the swastika type EBG is relocating towards the higher frequency region; This phenomenon is due to the limitation of fabrication which keeps a small chasm between the EBG and the 50 ohm line .The transmission response and bandwidth of swastika type EBG desirable than the Mushroom and Cross hair EBG's.

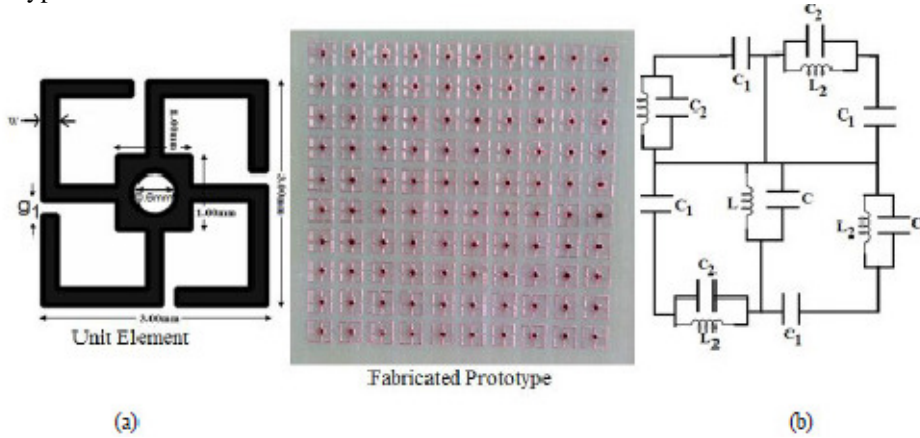

Figure 6(a).Swastika Type EBG Unit element 6(b)Equivalent circuit

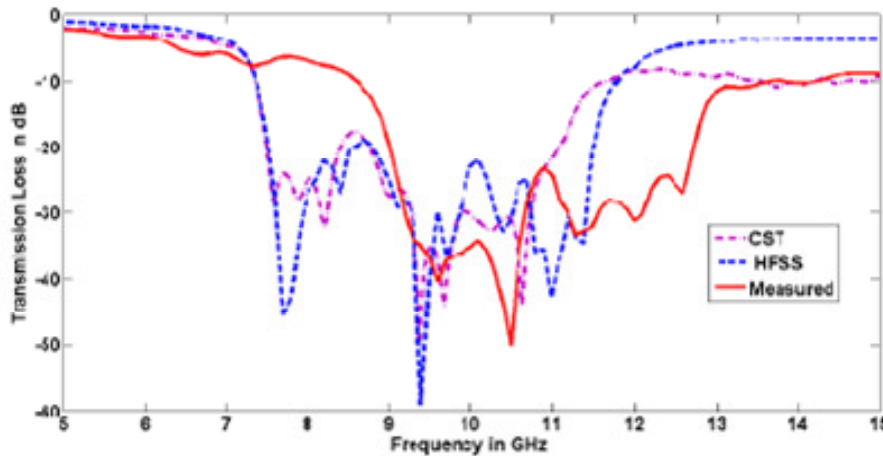

Figure 7. Different transmission responses of Swastika type EBG

Figure8. demonstrates how the alteration in width of strip g_1 changes the transmission response. It can be observed from the figure that an augmentation in g_1 causes the resonance frequency to relocate towards the higher frequency side due to reduction in the capacitance value. It is also analysed that as gap g_1 augments, the bandwidth augments (if -15dB bandwidth is considered). Figure 9. Demonstrates how the diameter variation impacts the transmission response of this EBG.

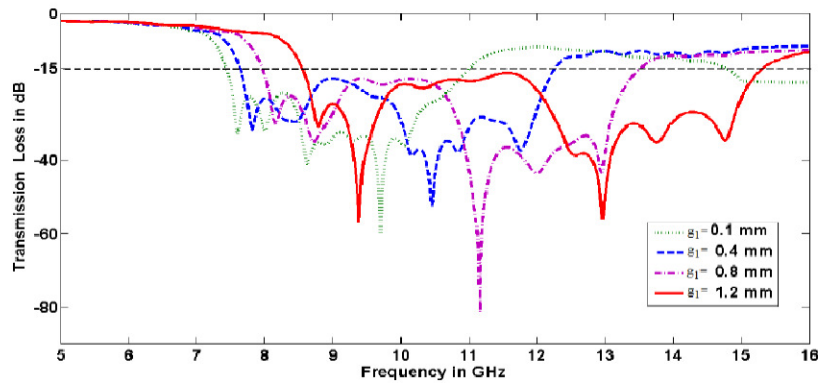

Figure 8. Impact of alteration of distance between the strips 'g1' on transmission response of Swastika type EBG (with $w = 0.2$ mm and $s = 1$ mm).

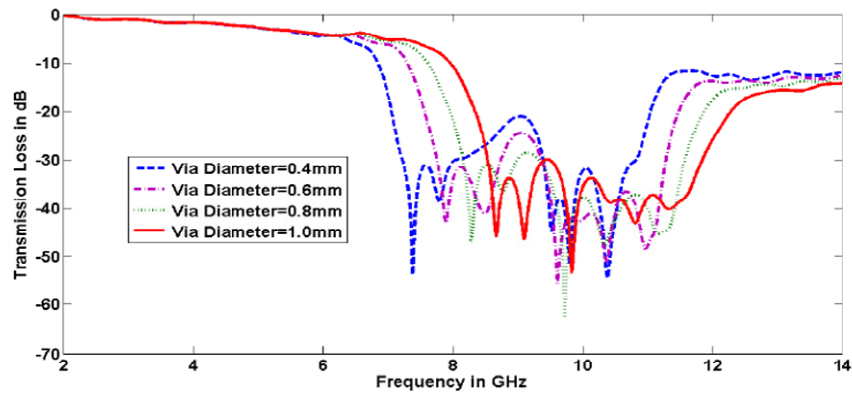

Figure 9. Impact of via diameter variation on transmission response of Swastika type EBG

Figure 10. Demonstrates transmission responses of the three EBGs. It is clear from the figure that the minimum frequency of operation and maximum bandwidth are possessed by the swastika type EBG. The Cross Hair type EBG has an advantage of lower frequency of operation compared to the mushroom type EBG.

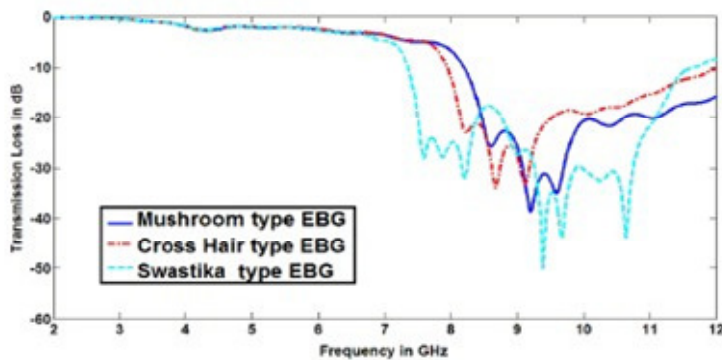

Figure 10. Juxtaposition of transmission responses of mushroom type, Cross Hair type and Swastika type EBG

Hexagonal patch type EBG

In a mushroom type EBG instead of using a rectangular patch a hexagonal patch of side length 4mm and via diameter of 1.0mm is used. FR-4 of width 1.53mm is used as the substrate. Figure 11 (a) represents the model of EBG of hexagonal patch. Figure 11(b) demonstrates transmission response. The bandwidth obtained is 1 GHz (3.65 GHz to 4.65 GHz).

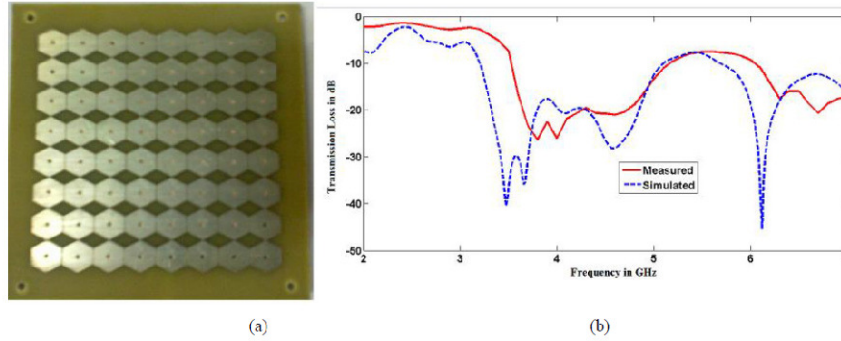

Figure 11. Hexagonal patch type EBG (a) fabricated prototype and (b) Measured and Simulated transmission response.

Table 1. Cut-off frequencies and Bandwidths of mono band EBGs

S.No	TYPE OF EBG	LOWER CUT OFF FREQUENCY(GHz)	Higher cut-off frequency (GHz)	Bandwidth (GHz)
1)Mushroom	3 mm x 3 mm	8.50	10.50	2.00
	4 mm x 4 mm	6.64	7.96	1.32
	5 mm x 5 mm	5.44	6.56	1.12
2)Cross Hair	3 mm x 3 mm	9.10	11.38	2.28
	4 mm x 4 mm	6.18	7.36	1.18
	5 mm x 5 mm	5.00	6.00	1.00
3)Swastika	3 mm x 3 mm	7.50	11.10	3.60
4) Hexagonal patch	(8 mm x 8 mm)	3.26	4.93	1.67

From the table it can be inferred that the Swastika type EBG is better in the aspects of dimensions and bandwidth.

3. DOUBLE BAND EBG

The micro strip circuit is cyclical in nature, This attribute can be utilized to develop a doubles band EBG. Although a double band nature can be generated by all EBG's, the dimensions and geometry play an important role to get double band in the required frequency range. Here, three different types of are fabricated for double band and their attributes are juxtaposed with a mushroom type EBG of similar dimensions. The transmission characteristics of a mushroom type EBG fabricated for double band and the transmission characteristic of solid ground is juxtaposed in Figure 11. Using mushroom type EBG's of two different sizes (8 mm x 8mm and 6 mm x 6mm) . The substrate has a width of 1.53 mm, via diameter is 1 mm and the distance between the unit elements is 1 mm. It is clear from the figure that an augmentation in the size of the EBG relocates the bands towards the lower frequency region because of augmentation in the capacitance.

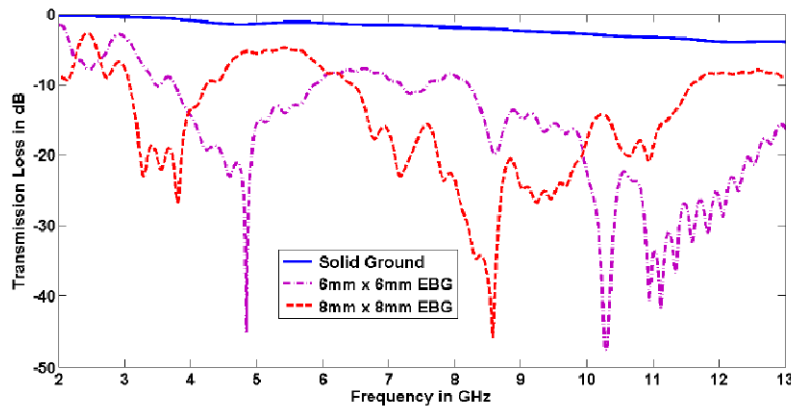

Figure 11. Juxtaposition of Simulated transmission response of solid ground and mushroom type EBGs of different size (Substrate thickness=1.53 mm, via diameter=1 mm, Gap between unit elements=1 mm)

Hexagonal patch (Double C Type Slot)

Figure 12 (a) demonstrates EBG of 'C' type slot and Figure 12(b) demonstrates the transmission responses for various slot widths. It can be understood from Figure 12(b) that an augmentation in the slot width makes the band relocate towards the lower frequency region due to augmentation in inductance.

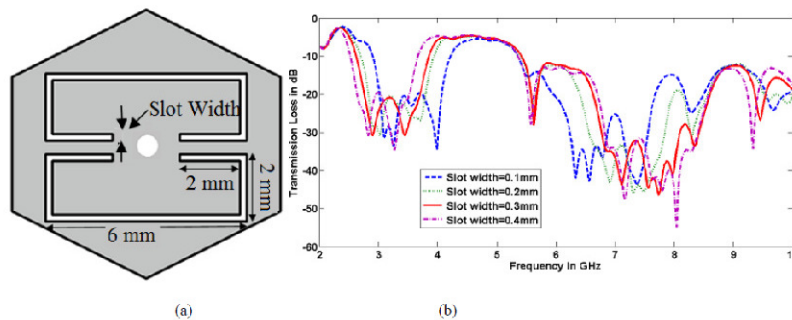

Figure 12. Hexagonal patch with C type slot EBG (a) Unit element (b) Transmission response for different slot width.

EBG with Square patch of mono disconnected loop type slot

Figure 13(a) demonstrates the unit element of this EBG. Slicing a slot in the patch generates an extra inductance and therefore it relocates the bands towards the lower frequency region. Figure 13(b) demonstrates the transmission responses. Figure 14 demonstrates how the width of slot impacts the transmission response of the EBG. It is clear from Figure 14 that an augmentation in the slot width makes the lower band relocate towards the lower frequency region.

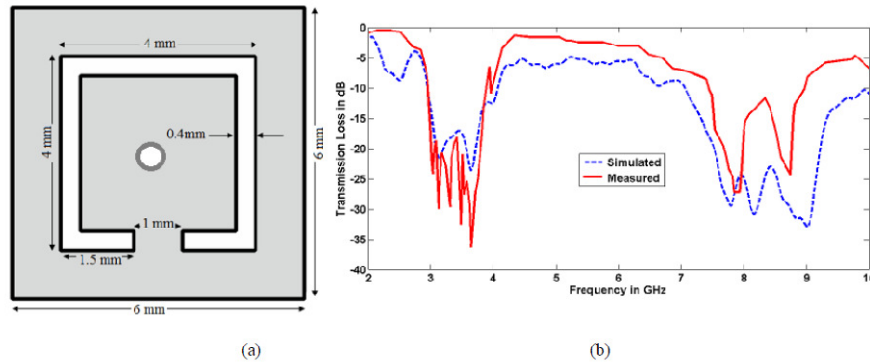

Figure 13. Square patch with single disconnected loop type slot type EBG (a) Unit element (b) Measured and simulated transmission response.

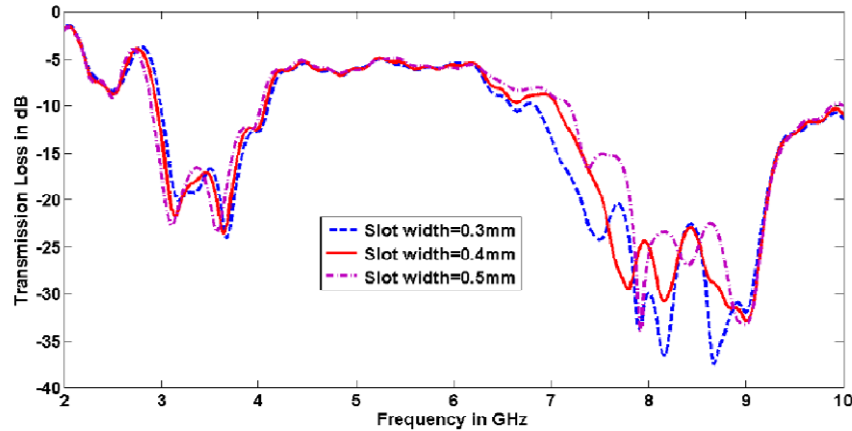

Figure 14. Effect of slot width on transmission response of Square patch with single disconnected loop type slot EBG

The distribution of current in the EBG of disconnected loop type slot is demonstrated by Figure 15 . The largest value of current density is denoted by red colour whereas the least value of the current density is denoted by blue colour .It is clear from the figure that at stop band frequencies of EBG, as the signal travels from one port to the other port it gets attenuated. At 6.0 GHz, the signal is not attenuated and the attenuation at 8.0 GHz is more compared to that of the attenuation at 3.6GHz.

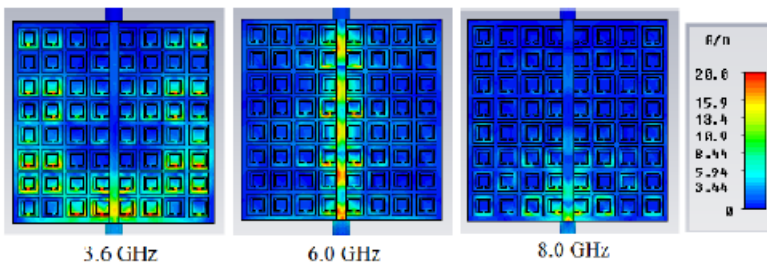

Figure 15. Distribution of current for a square patch at various frequencies

EBG of fractal Type

The Fabrication of fractal type ebg of unit element size 6mm*6mm is done. Figure 16 demonstrates the unit element of this EBG. Its characteristics are more desirable than EBG. The minimized dimensions for the fractal EBG are $X = 2$ millimeters $Y = 1.4$ millimeters, $A = B = 0.6$ millimeters, $g = 0.8$ millimeters. The via diameter is 1.2 mm. Figure 17 demonstrates how the alteration in the width of slot changes the transmission response of the EBG. From Figure 17 it can be understood that after a specific value of slot width the band gets divided. The minimal value of the width of the slot is obtained as 1.4 mm and the is lower frequency band is unaffected by the width of the slot and the impact of separation between unit elements is demonstrated by Figure 18. It is observed that the separation 'g' affects the higher band bandwidth. The ideal value of 'g' is obtained as 0.8 mm.

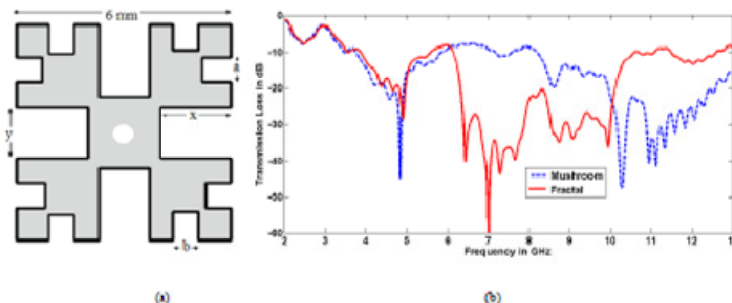

Figure 16. Fractal type EBG (a) Unit element (b) Transmission response comparison of fractal and conventional mushroom type element having equal unit element size.

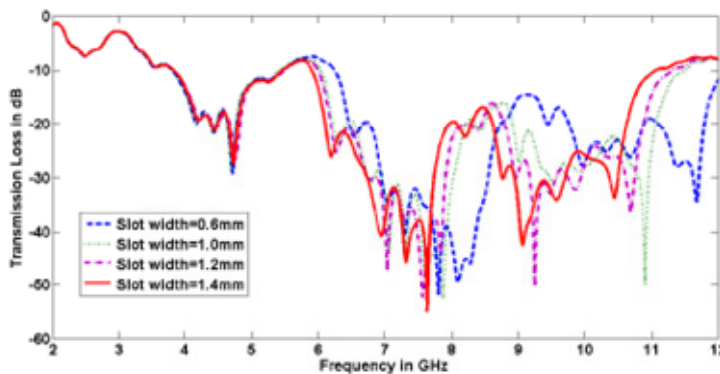

Figure 17. Impact of slot width 'y' variation on transmission response of the fractal EBG ($x = 2$ mm, $a = b = 0.6$ mm, $g = 0.5$ mm)

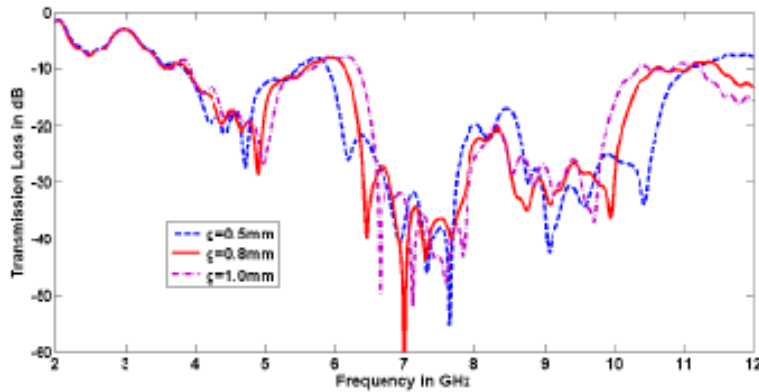

Figure 18. Impact of gap ‘g’ variation between unit elements on transmission response of the fractal EBG (x = 2 mm, y = 1.4 mm, a = b = 0.6 mm)

Table 2. Bandwidths and Cut-off frequencies of various double band EBGs

S.No	Type of EBG		Lower Band			Higher Band		
			LowerCut-off Freq(GHz)	Higher Cut-off Freq(GHz)	Bandwidth (GHz)	LowerCut-off Freq(GHz)	Higher Cut-off Freq (GHz)	Bandwid th(GHz)
1	Mush-room	6mm*6 mm	4.22	4.95	0.73	9.92	12.60	2.68
		8mm*8 mm	3.23	3.87	0.65	7.74	9.95	2.21
2	Hexagonal patch with Double c Type Slot	(8mm*8 mm)	2.74	3.75	1.01	6.60	8.63	2.03
3	Square patch with mono disconnected loop type slot	(6mm*6 mm)	3.11	3.77	0.66	7.28	9.25	1.97
4	Fractal EBG	(6mm*6 mm)	4.22	4.92	0.70	6.66	10.35	3.69

From the table, it is verified that slicing a slot relocates the band to the lower frequency region thereby compactness can be obtained . For an ebg of mushroom type and fractal type the cut-off frequency and bandwidth for the lower band are equal .But, its bandwidth is more in the upper band than the mushroom type EBG.

4. CONCLUSIONS

Various Electromagnetic Band Gap Structures for mono and double band operation in the Ultra Wide Band region are scrutinized. An augmentation in the unit size causes the capacitance to increase which makes the stop band shift towards the lower frequency region due to an augmentation in the capacitance. Augmentation in the distance between the unit elements relocates the stop bands towards higher frequency region due to reduction in the capacitance. Augmentation in the via diameter reduces the inductance which in turn relocates the stop bands towards higher frequency region. Out of all single band EBGs, the swastika type EBG offers better performance in both compactness (lower resonance frequency) and bandwidth. Out of all double band EBGs the fractal type has better bandwidth. The proffered EBGs are used for boosting the gain of antenna bandwidth, signal integrity and obstruction of noise in fast switching circuits.

5. ACKNOWLEDGEMENTS

This research paper is made possible through the help and support of K.Praveen Kumar. I would like to thank k. Praveen Kumar for his support and encouragement.

REFERENCES

- [1] D. Sievenpiper, "High-impedance Electromagnetic Surfaces", Ph. D. dissertation, Department of Electrical Engineering, University of California at Los Angeles, Los Angeles, CA, 1999.
- [2] Fan Yang and Yahya Rahmat Samii, "Electromagnetic Band Gap Structures in Antenna Engineering", Cambridge university press 2009.
- [3] Y. Lee, J. Yeo, K. Ko, Y. Lee, W. Park, and R. Mittra, "A novel design technique for control of defect frequencies of an electromagnetic band gap (EBG) cover for dual band directivity enhancement", *Microw. Opt. Technol. Lett.*, vol. 42, no. 1, pp. 25–31, Jul. 2004.
- [4] A. Pirhadi, F. Keshmiri, M. Hakkak and M. Tayarani, "Analysis and Design of Dual Band High Directive EBG Resonator Antenna Using Square Loop FSS as Superstrate Layer", *Progress In Electromagnetics Research PIER*, vol. 70, pp.1-20, 2007.
- [5] D. Sievenpiper, L. Zhang, R.F. Jimenez Broas, N. G. Alexopoulos, and E. Yablonovitch, "High-impedance electromagnetic surfaces with a forbidden frequency band", *IEEE Trans. Microwave Theory Techn.*, vol.47, pp. 2059-2074, Nov. 1999.
- [6] Li Yang; Mingyan Fan; Fanglu Chen; Jingzhao She; ZhengheFeng, "A novel compact electromagnetic-bandgap (EBG) structure and its applications for microwave circuits", *Microwave Theory and Techniques, IEEE Transactions on* , vol.53, no.1, pp.183-190, Jan. 2005.
- [7] Sai Wai Wong; Lei Zhu, "EBG-Embedded Multiple-Mode Resonator for UWB Band Pass Filter With Improved Upper-Stop band Performance", *Microwave and Wireless Components Letters, IEEE* , vol.17, no.6, pp.421,423, June 2007.
- [8] J. F. Frigon, C. Caloz, and Y. Zhao, "Dynamic radiation pattern diversity (DRPD) MIMO using CRLH leaky-wave antennas", *Proc. IEEE Radio Wireless Symp.*, Jan. 2008, pp. 635–638.
- [9] P. N. Fletcher, M. Dean, and A. R. Nix, "Mutual coupling in multi element array antennas and its influence on MIMO channel capacity", *Electron. Lett.*, vol. 39, pp. 342–344, Feb. 2003.
- [10] Payandehjoo, Kasra and Abhari Ramesh, "Employing EBG Structures in Multiantenna Systems for Improving Isolation and Diversity Gain", *IEEE Antennas and Wireless Propagation Letters*, vol. 8, pp. 1162-1165, 2009.
- [11] Mohamad Yajdi and Nader Komjani, "Design of a band notched Ultra wideband antenna by means of EBG structure", *IEEE Antenna propagation letters*, VOL. 10, pp. 170-173, 2011.
- [12] R. Abhari and G. V. Eleftheriades, "Metallo-dielectric electromagnetic band gap structures for suppression and isolation of the parallel-plate noise in high-speed circuits", *IEEE Trans. Microw. Theory Tech.*, vol.51, no.6, pp.1629–1639, Jun. 2003.
- [13] S.Shahparnia and O.M. Ramahi, "Miniaturized electromagnetic band gap structures for broadband switching noise suppression in PCBs", *Electron. Lett.*, vol.41, no.9, pp.519–520, Apr. 2005.

- [14] T. L. Wu, Y. H. Lin, T. K. Wang, C. C. Wang, and S. T. Chen, "Electromagnetic bandgap power/ground planes for wideband suppression of ground bounce noise and radiated emission in high-speed circuits", IEEE Trans. Microw. Theory Tech., vol. 53, no. 9, pp. 2935–2942, Sep. 2005.
- [15] Jie Qin; Ramahi, M. Omar, V. Granatstein, "Novel Planar Electromagnetic Bandgap Structures for Mitigation of Switching Noise and EMI Reduction in High-Speed Circuits", Electromagnetic Compatibility, IEEE Transactions on , vol.49, no.3, pp.661,669, Aug. 2007.
- [16] F. De Paulis and A. Orlandi, "Accurate and efficient analysis of planar electromagnetic band-gap structures for power bus noise mitigation in the GHz band", Progress In Electromagnetics Research B, Vol. 37, 59-80, 2012.
- [17] S. Shahparnia, Ramahi, M. Omar, "A simple and effective model for electromagnetic bandgap structures embedded in printed circuit boards", Microwave and Wireless Components Letters, IEEE , vol.15, no.10, pp.621,623, Oct. 2005.
- [18] Elek, Francis, G.V. Eleftheriades, "Dispersion analysis of the shielded Sievenpiper structure using multiconductor transmission-line theory", Microwave and Wireless Components Letters, IEEE , vol.14, no.9, pp.434,436, Sept. 2004.
- [19] L. Peng, C. L. Ruan, and J. Xiong. "Compact EBG for multi-band applications" IEEE Transactions on Antennas and Propagation, vol. 60, pp. 4440-4444, 2012.
- [20] X. L. Bao, G. Ruvio, and M. J. Ammann, "Low-profile dual-frequency GPS patch antenna enhanced with dual-band EBG structure," Microw. Opt. Technol. Lett., vol. 49, no. 11, pp. 2630,-2634, Nov. 2007.
- [21] T. Kamgaing, and O. M. Ramahi, "Multiband Electromagnetic-Bandgap Structures for Applications in Small Form-Factor Multichip Module Packages," IEEE Trans. Microw. Theory Tech., vol. 56, no. 10, pp. 2293-2300, Oct. 2008.
- [22] Lin Peng; Cheng-Li Ruan; Li, Zhi-Qiang, "A Novel Compact and Polarization-Dependent Mushroom-Type EBG Using CSRR for Dual/Triple-Band Applications," Microwave and Wireless Components Letters, IEEE , vol.20, no.9, pp.489,491, Sept. 2010.

Authors

D.Rohith was born in india, A.P in 1991. He received B.Tech(ECE) from Jawaharlal Nehru Technological University, Hyderabad and M.Tech(EmbeddedSystems) from Gitam University,Visakhapatnam and working as an Assistant Professor in MLRIT,Hyderabad.



N.Pallavi was born in india, A.P in 1989. She received B.Tech(ECE) from Jawaharlal Nehru Technological University, Hyderabad and M.Tech (Digital systems and computer electronics)from Jawaharlal Nehru Technological University, Hyderabad and working as an Assistant Professor in MLRIT,Hyderabad.



B.Annapurna was born in India, A.P in 1990. She received B.Tech(ECE) from Jawaharlal NehruTechnological University, Hyderabadand M.Tech(Digital systems and computer electronics)from Jawaharlal Nehru Technological University, Hyderabad and working as an Assistant Professor in MLRIT, Hyderabad.



K..Praveen Kumar was born in india, A.P in 1980. He received B.E(ECE) from Visveswaraiah Technological University, Belgaum. And M.Tech(Microwave Engg) Acharya Nagarjuna University, Guntur.He has a 10 years of teaching experience. 11 International Journals, 01 International Conference in his credit. He is a research scholar of JNT University, Hyderabad. In the field of Microwave Antenna. He had held the responsibility of HOD for dept of ECE at Sri Vani School of Engineering, Chevutur and presently working as an Associate professor in MLRIT, Hyderabad.

