

# DESIGN AND DEVELOPMENT OF WIND TURBINE EMULATOR TO OPERATE WITH 1.5KW INDUCTION GENERATOR

Himani <sup>#1</sup>, Dr.Ratna Dahiya <sup>\*2</sup>

Department of Electrical Engineering, National Institute of Technology, Kurukshetra  
Haryana ( India)

## Abstract

*This paper contributes to design a Wind Emulator coupled to 1.5 kW Induction generator for Wind Energy Conversion System. A wind turbine emulator (WTE) is important equipment for developing wind energy conversion systems. It offers a controllable test environment that allows the evaluation and improvement of control schemes for electric generators that is hard to achieve with an actual wind turbine since the wind speed varies randomly. In this paper a wind emulator is modelled and simulated using MATLAB. Verification of the simulation results is done by experimental setup using DC motor-Induction generator set, LABVIEW and data acquisition card.*

## Keywords

*Wind Turbine; Emulator; LABVIEW; Matlab; Self excited induction generator*

## I. INTRODUCTION

With the increase in demand for wind power tremendous R&D efforts are involved such as testing advanced control strategies, maximum power point tracking algorithms etc. DSP and LabVIEW are the most advanced methods for monitoring condition of Wind Turbine Systems. A real wind turbine may not always be available for R&D so the provision of a controllable experimental platform without reliance on natural wind resources is very important. Wind Turbine Emulator (WTE) is an equipment for developing wind energy conversion system used for research applications. WTE drives an electrical generator in a similar way as a Wind Turbine, by reproducing the torque developed for a given wind velocity Also, it can be used as an educational tool to teach the behaviour, operation and control of a Wind Turbine .

Over the past years a lot of research has been made on wind turbine emulator in which different kinds of prime movers have been used in realizing WTE. A DC motor is easy to implement, so most of the Wind Turbine Emulators are based on separately-excited DC machine [1-7]

An experimental setup that consists of a wind turbine model, with a separately excited DC motor coupled to a permanent magnet synchronous generator (PMSG) to emulate wind turbine rotor speed is presented in detail [2]. W. LI et al.[5]also used DC motor but coupled to doubly fed induction generator (DFIG) with a control program developed using C-language and implemented using digital signal processor (DSP), which generates the speed or torque signals to a DC drive through D/A converter. Whereas an IGBT inverter controlled (IM) has been used as a Wind Turbine Simulator (WTS) [10] [11].The armature current and frequency demand values were controlled in such a way that the IM shaft generated the steady-state characteristics of a constant pitch wind turbine.

Brushless DC motor [13] and Permanent Magnet Synchronous motor (PMSM) [14] are also used as prime movers for implementing WTE. Induction generator simulation has been presented in detail [15]-[17].

This paper contributes to design a Wind Emulator coupled to 1.5 kW Induction generator for Wind Energy Conversion System. The turbine torque and rotation are both simulated according to wind speed and load conditions. A detailed description of Wind Emulator along with simulation and experimental results are shown in following sections.

## II. DEVELOPMENT OF WIND TURBINE EMULATOR

### A. Wind Turbine Modeling

The wind turbine operates on the principle of aerodynamics. The Power output of the turbine is given as [3]:

$$P = \frac{1}{2} \rho C_p A v^3 \quad (1)$$

The amount of power available from wind is a function of the velocity of the wind cubed. Therefore, even a small increase in wind velocity will lead to an exponential increase in available power. Here,  $\rho$ ,  $v$ ,  $A$  and  $C_p$  are air density, wind speed, angular speed of blades and power coefficient respectively. Power coefficient  $C_p$  defines the ability of a wind turbine to capture wind energy through the ratio of extracted power to wind power. It is a function of both pitch angle ( $\beta$ ) and tip speed ratio ( $\lambda$ )

$$C_p = f(\beta, \lambda) \quad (2)$$

For fixed pitch WT ( $\beta = 0^\circ$ ) the only factor affecting the power coefficient is the tip speed ratio ( $\lambda$ ), which is given by

$$\lambda = \omega R / v \quad (3)$$

Where,  $\omega$  is the rotor angular velocity (rad/s),  $R$  is radius of the aerodynamic disk of a wind turbine.

The numerical approximation of power coefficient is given by:

$$C_p(\lambda, \beta) = C_1 \left( \frac{C_2}{\lambda_i} - C_3 \beta - C_4 \right) e^{-C_5 / \lambda_i} + C_6 \lambda \quad (4)$$

$$1 / \lambda_i = 1 / (\lambda + 0.08 \beta) - 0.035 / (\beta^3 + 1) \quad (5)$$

With

$$C_1 = 0.5, C_2 = 116, C_3 = 0.4, C_4 = 5, C_5 = 21, C_6 = 0 \quad (6)$$

The power co-efficient  $C_p$  and Wind Turbine power  $P$  are calculated using the equations (1-6). The reference torque is obtained by dividing the WT power with angular speed. The relationship between  $C_p, \lambda$  at a pitch angle of zero radians is plotted in Fig1.

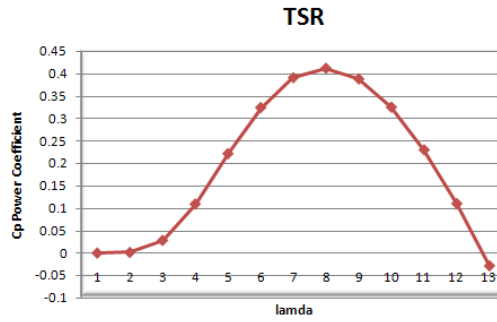

Fig. 1 Illustration of power coefficient vs, tip speed ratio

The above characteristic is same for all wind speeds below the rated wind speed, provided the pitch angle is maintained at zero. The mechanical torque generated can be calculated from the WT power and the shaft speed as given by:

$$T = \frac{P}{\omega} \quad (6)$$

### B. Wind Turbine Emulation Based on DC Motor

In this research, a horizontal axis wind turbine is emulated using a DC motor as WT. The Proposed emulator is shown in Fig.2. Steady-state characteristics of a given wind turbine at various wind velocity is simulated. The wind speed, turbine radius and angular speed of motor are considered as inputs of this model. To calculate the reference torque, the control program reads wind velocity from an input file, shaft speed from Tacho generator and supply current from current transducer. The wind data file can be generated in different ways, depending on the desired test conditions, or even being real data from an anemometer.

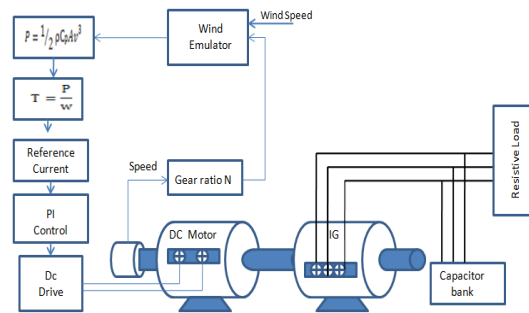

Fig 2. Structure of WTE using DC motor and Induction generator

The electromagnetic torque of a DC motor should be equal to the reference torque of wind turbine. From the mathematical model, it is easy to obtain the reference armature current  $I_{aref}$  which is used to control the armature current of the DC motor by using PI controller and semi converter rectifier. It gives controlled rectified voltage depending upon the triggering pulses to thyristors, for the regulation of DC motor armature voltage. The variation in armature voltage controls the motor current in accordance with the reference current and the system reaches a steady state. Here, the dc motor current is directly controlled so that the required torque is directly proportional to the current.

### C. Simulation of Wind turbine using MATLAB

MATLAB/ SIMULINK model of wind turbine emulator established using the equations (1-6) are shown in Fig.3. It comprises of dc motor, semi converter, PI and firing angle controller.

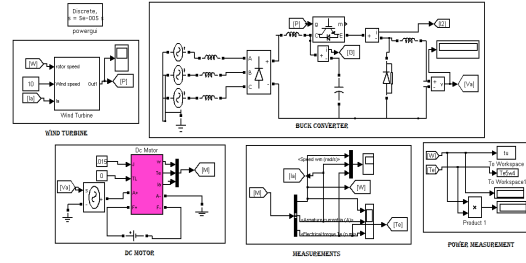

Fig 3. MATLAB model of Wind Turbine Emulator

Fig.4 shows an equivalent circuit model of separately excited dc motor. To implement the dc motor model its dynamic characteristics is essential.

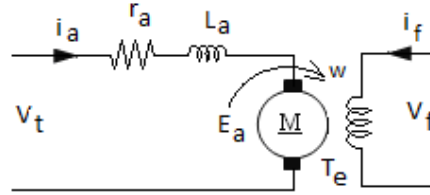

Fig. 4 Equivalent of DC motor

From Fig.4, the dynamic equation of the dc motor is given by

$$T_e - T_L = J \frac{d\omega}{dt} \quad (7)$$

$$T_e = C_T \Phi i_a \quad (8)$$

$$V_t = r_a i_a + L_a \frac{di_a}{dt} + C_T \Phi \omega \quad (9)$$

Where

$T_L$ : load torque

$T_e$ : Electromagnetic torque

$J$ : Moment of inertia,

$\omega$ : Rotational speed

$L_a$ : Armature inductance

$C_T$ : Torque constant.

Using equations (7-9), the dynamic characteristic of the motor is given by:

$$\frac{d}{dt} \begin{bmatrix} i_a \\ \omega \end{bmatrix} = \begin{bmatrix} -\frac{r_a}{L_a} & -\frac{C_T \Phi}{L_a} \\ \frac{C_T \Phi}{J} & 0 \end{bmatrix} \begin{bmatrix} i_a \\ \omega \end{bmatrix} + \begin{bmatrix} \frac{1}{L_a} & 0 \\ 0 & -\frac{1}{J} \end{bmatrix} \begin{bmatrix} V_t \\ T_L \end{bmatrix} \quad (10)$$

MATLAB/SIMULINK model of a separately excited DC motor implemented using equation (10) is shown in Fig.5.

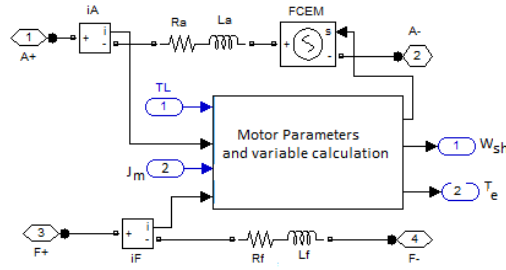

Fig 5 Model of separately excited dc motor

The inputs to the DC motor model are the applied armature voltage, field voltage, the motor inertia and load torque, and output is speed, armature current and electromagnetic torque. These parameters of dc motor were obtained following the test procedures and are presented in Appendix-B.

The reference current for the average value of the armature current is calculated as a function of the wind speed and wind turbine speed to produce the average aerodynamic torque of the wind from the control algorithm of wind turbine simulation system as shown in Fig.6.

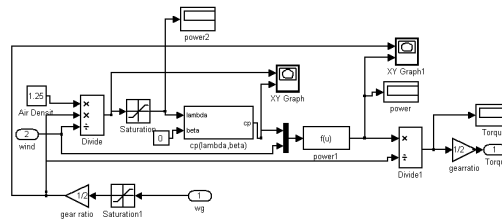

Fig 6.Estimation of reference torque

The controller shown in Fig.7 is configured to operate in full wave half controlled DC motor drive mode with a PI controller intended for the use with DC machines to regulate the speed or current. The PI controller compares the actual armature current to its set point and then generates an analog firing signal as an output which is connected to a driver control unit that converts this analog firing signal into train of pulses that controls the armature current ..

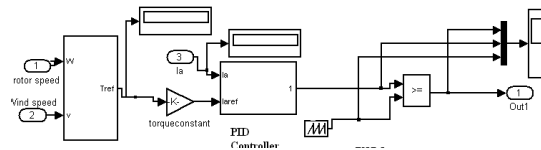

Fig 7. PI controlled pulse generation circuit

### D. Self-Excited Induction Generator

Induction motor is used as a generator in wind energy conversion scheme as shown in Fig.8.If the rotor rotates above the synchronous speed of the rotating magnetic field (RMF), emf is induced in the stator winding if provided with remanent magnetic field in the rotor circuit. The generated emf builds up to the rated value by the external capacitor connected across the stator winding making it self-excited induction genrator (SEIG).

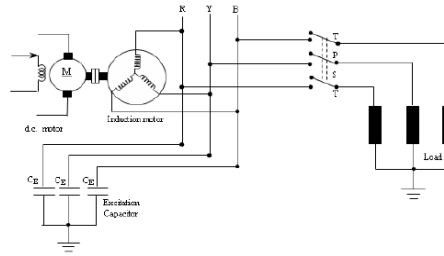

Fig 8 . Schematic circuit of proposed system

Simulation study of the proposed system of the Wind turbine driven SEIG with suitable capacitor bank and load is conducted in Matlab as shown Fig 9.

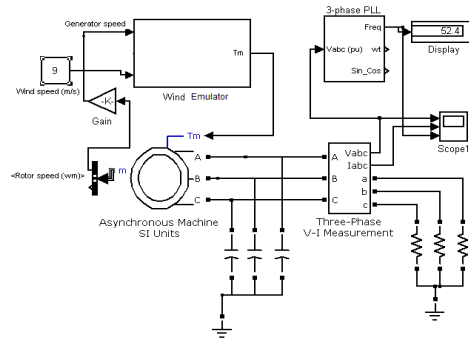

Fig.9 Simulation circuit of wind driven induction generator supplying three-phase resistive load

### III. SIMULATION RESULTS AND DISCUSSION

Fig. 10(a-b) demonstrates the results during emulator operation. The wind profile used to carry out simulation for step variations in wind speed from 4 -12 m/s, and a load torque TL of 0.42 Nm is shown in (a) and the variation in DC Motor speed (b) shows that it accurately follows the speed of turbine model.

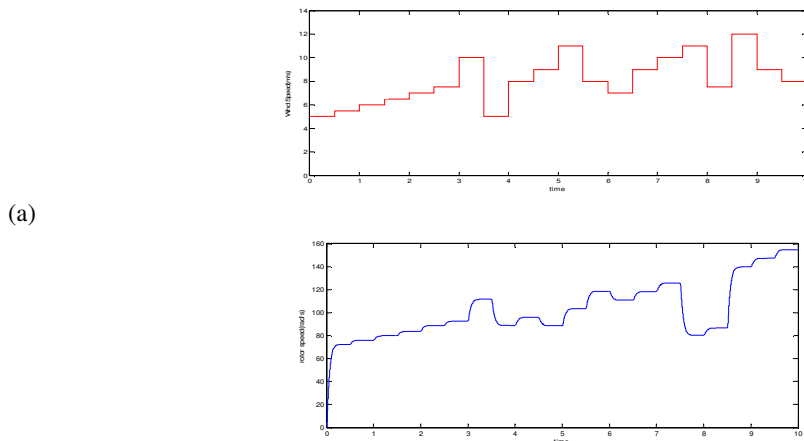

Fig.10 Wind turbine Response in Simulation  
(a)Step response of windspeed (b)DC motor speed

Fig. 11 shows excitation voltage at the stator terminals of SEIG on no load and wind speed of 9m/s.

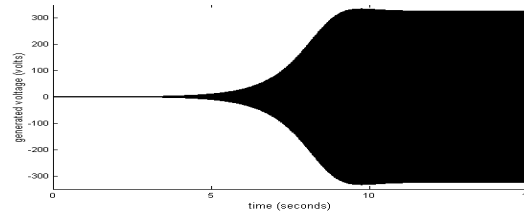

Fig. 11 Voltage buildup of SEIG at no-load

#### IV. EXPERIMENTAL WORK

The realization of the wind turbine is made in this study by DC motor controlled three-phase self-excited induction generator as shown in Fig 12. The whole setup comprises of a system with a real wind profile, Advantech-4074 based Data acquisition system, DC motor with DC drive, signal conditioner and a SEIG with three phase excitation capacitor bank and three phase load. The wind turbine model and the PI controller are developed on a LABVIEW platform.

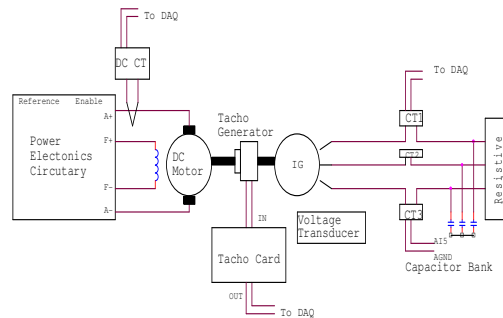

Fig. 12 Block diagram of Experimental setup

Transducers are used to measure the shaft rotational speed and armature current at the motor side and three phase voltage and current at the terminals of the generator. Data acquisition equipment is installed for computer interfacing.



Fig. 13. Photograph of experimental setup

The setup is designed to control the torque of the DC motor by regulating the motor terminal voltage while maintaining constant field current. Semi Converter Bridge gives controlled rectified voltage depending upon the triggering pulses. This voltage is fed to the armature of the dc motor

for torque control. The input for Induction generator is this controlled mechanical torque developed by the DC motor according to wind turbine equations.

The output voltage profile of the SEIG is observed experimentally for no load and variable load conditions. The voltage waveforms are shown in Fig.14 (a-c). At no load the machine takes few seconds to excite and generate output voltage. The magnitude of peak to peak AC output voltage at no load is 8.5 V and equivalently 400V as a Potential transformer (PT) has been used to step down the generated 440 V to .. V the maximum analog input (AI) range of data acquisition card (a).

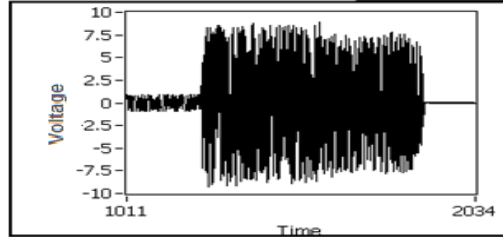

Fig.14(a)Excitation Voltage on no load condition at wind speed of 10m/s

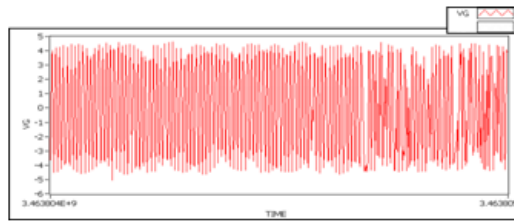

Fig.14(b)Voltage O/p on different load conditions at wind speed of 10 m/s

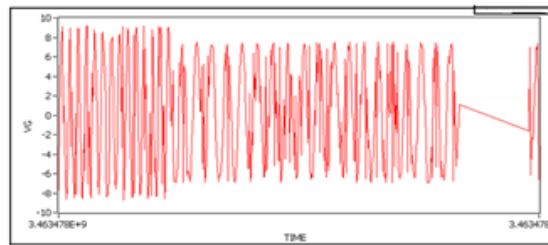

Fig.14(c) Voltage O/p with a step variations in wind speed

The output voltage magnitude decreases to 220 V when a resistive load of 300  $\Omega$  is applied to the stator terminals of SEIG(b).This is because on loading the motor the machine current drawn from SEIG increases. The output voltage for step variations in wind speed is shown in (c). The experimental results confirm the feasibility and performance of the proposed WTE with LABVIEW providing the platform for interfacing.

## V.CONCLUSION

The challenges of Wind Energy conversation system study are the non linear behavior of WT and erratic nature of wind .To overcome such problem a WTE is designed, developed and installed with a Dc motor induction generator set. The wind profiles are investigated in LABVIEW and the



response of Dc Motor is studied. The experimental results confirm the feasibility and performance of Emulator. This work helps in carrying out wind turbine related studies in regions where the natural wind resource is unavailable, with experimental setups at low power scale.

#### Appendix-A

Table 1 Wind Turbine Parameters

|                   |           |
|-------------------|-----------|
| Rated power       | 800 Watts |
| Rated wind Speed  | 10 m/sec  |
| Radius of WT      | 1.4 m     |
| Power coefficient | 0.48      |

#### Appendix-B

Table 2 DC Motor Parameters

|                          |             |
|--------------------------|-------------|
| Rated power              | 2.5kW       |
| Nominal Speed            | 1750 rpm    |
| Armature resistance (Ra) | 1.8711 ohms |
| Filed resistance (Rf)    | 470 ohms    |
| Armature inductance (La) | 98mH        |
| Filed inductance (Lf)    | 14.160H     |

#### Appendix-C

Table 3 Induction Generator Parameters

|               |          |
|---------------|----------|
| Rated power   | 1 kW     |
| Nominal Speed | 1500 rpm |

### ACKNOWLEDGMENT

The research was supported by a NIT Kurukshetra and ABES College of Engineering & Tech Ghaziabad.. The authors are grateful for the support.

### REFERENCES

- [1] Selman Kouadria, Seifeddine Belfedhal and Youcef Meslem El Madjid Berkouk, "Development of real time Wind Turbine Emulator based on DC Motor controlled by hysteresis regulator," Renewable and Sustainable Energy Conference (IRSEC), 2013 International ,7-9 March 2013, p. 246 – 250
- [2] Bagh, S.K. , Samuel P. , Sharma R., Banerjee, S."Emulation of static and dynamic characteristics of a Wind turbine using Matlab/Simulink" International Conference on Power, Control and Embedded Systems (ICPCES), 2012 Page(s): 1 - 6
- [3] A.S.Satpathy, N.C.Sahoo, " Development of control scheme for a stand-alone wind system: Wind turbine emulated using DC motor ", in IEEE Students' Conference of Electrical, Electronics and Computer Science, 2012, p. 1–4
- [4] M.Monfared, H.MadadiKojabadi, H.Rastegar, " Static and dynamic wind turbine simulator using a converter controlled dc motor ", Renewable Energy, vol. 33, no. 5, p. 906–913, 2008
- [5] W.Li, D.Xu, W.Zhang, H.Ma, " Research on wind turbine emulation based on DC motor ", in 2nd IEEE Conference Industrial Electronics and Applications, 2007, p. 2589–2593
- [6] B. Rabelo and W Hofmann "Emulation of the Static and Dynamic Behavior of a Wind turbine with a DC Machine Drive" PESC'04,Aachen, Germany, 2004, pp.2107-21
- [7] M.Arifujjaman, " Emulation of a small wind turbine system with a separately-excited Dc machine ", IU-Journal of Electrical & Electronics Engineering, vol. 8, no. 1, 2012

- [8] R.I.Ovando, J.Aguayo, M.Cotorogea, “ Emulation of a low power wind turbine with a DC motor in Matlab/Simulink ”, in IEEE, Power Electronics Specialists Conference, 2007, p. 859–864
- [9] L.Qihui, H.E.Yikang, and Z.Rende, “Imitation of the Characteristics of the wind turbine based on DC motor,” *Frontiers of Electrical and Electronics Engineering in China*, vol. 2,issue 3, pp.361–367,2007
- [10] Bunlung Neammanee, Somporn Sirisumrannukul and Somchai Chatratana, (2007) “Development of a Wind Turbine Simulator for Wind Generator Testing” *International Energy Journal* 8, 21-28
- [11] HosseinMadadiKojabadi, Liuchen Chang and TobieBoutot. “Development of a Novel Wind Turbine Simulator for Wind Energy Conversion Systems Using an Inverter-Controlled Induction Motor”. *IEEE Transactions on Energy Conversion*, Vol. 19, No. 3, September 2004, pp.547–55
- [12] Honghao Guo,Bo Zhou, Jichen Li, Fangshun Cheng,” Real-time simulation of BLDC-based wind turbine emulator using RT-LAB”, *International Conference on Electrical Machines and Systems*, 2009. ICEMS 2009. P.1 – 6
- [13] W.Hu, Y.Wang, X.Song, Z.Wang.,“Development Of Wind Turbine Simulator For Wind Energy Conversion Systems Based On Permanent Magnet Synchronous Motor”, *International Conference of Electrical Machines and Systems*, 2008, p. 2322–2326.
- [14] K.Subramanian, K. K. Ray, Venkat and S. Aravind “ Experimental Based Capacitance Calculation Of Induction Motor: As wind power generator”, *International Conference on Sustainable Energy and Intelligent Systems (SEISCON 2011)*, p. 143 – 148
- [15] K.Subramanian, S.P. Sabberwal,”Cost Effective Wind Energy Conversion Scheme Using Self-Excited Induction Generator”,*Advanced Materials Research*,July 21, 2013, p. 143-150
- [16] Yu Zou Malik Elbuluk and Yilmaz Sozer,“A Complete Modeling and Simulation of Induction Generator Wind Power Systems,” *IEEE Industry Applications Society Annual Meeting (IAS)*, 2010, p.1 – 8
- [17] Yu Zou, Malik E. Elbuluk, and Yilmaz Sozer”Simulation Comparisons and Implementation of Induction Generator Wind Power”, *IEEE Transactions On Industry Applications*, Vol. 49, No. 3, May/June 2013

## Authors

Himani received her B.Tech in Electronics and Communication from SLIET Longowal, Punjab, India and M.Tech in Electronics and Communication from ITM University Gurgaon, Haryana, India. Currently, she is doing Ph.D. from National Institute of Technology, Kurukshetra (Deemed University), Haryana, India. Her research interests include Communication systems, Signal Processing and Power systems.



Dr. Ratna Dahiya received her B. tesh from GBU, Pant Nagar and M. Tech and Ph.D. drgree in Electrical engineering from from National Institute of Technology, Kurukshetra (Deemed University), Haryana, India. Currently, she is working as faculty in Electrical Engineering Department with the National Institute of Technology,Kurukshetra (Deemed University), Haryana, India. Her research interests include SMES, Induction Machines, ASD's, power quality, motor drives and Renewable energy.

